



# Single DOC200 Trap Tunnel

This document sets out construction detail for a DOC200 Trap Tunnel

The supplied trap tunnel kit contains stainless components – which provide excellent longevity in NZ’s largely coastal and semi-coastal environments.

This design has been field-proven to be reliable at excluding Weka & Kea breaking in to traps and getting injured.

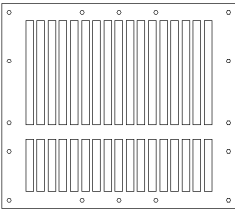
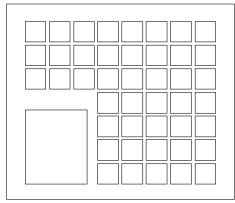
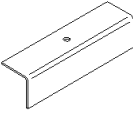
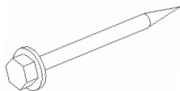
Kit contents ...

DOC200 SINGLE - HARDWARE		
PART ID	PART DESCRIPTION	QTY
A	DOC200 END GRILL 	2
B	DOC200 INTERNAL BAFFLE 	1
C	TOP SCREW BRACKET 	2
D	65 mm S/S SCREW 	2
E	30 mm S/S PAN HEAD SCREW 	16
F	75 mm S/S DECKING NAIL 	18

Cut Timber Components ...

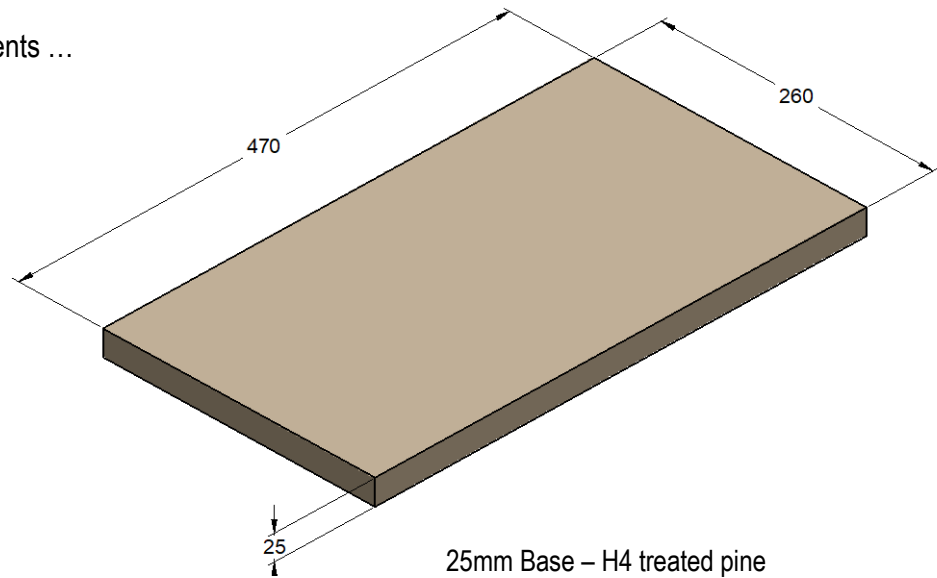

25mm Base – H4 treated pine

**1 Required**

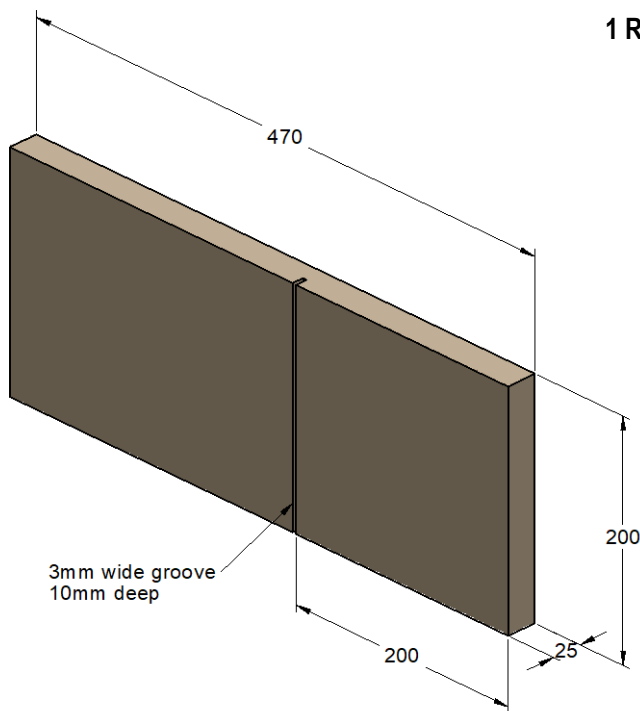

25mm LH Side – H3.2 treated pine

**1 Required**

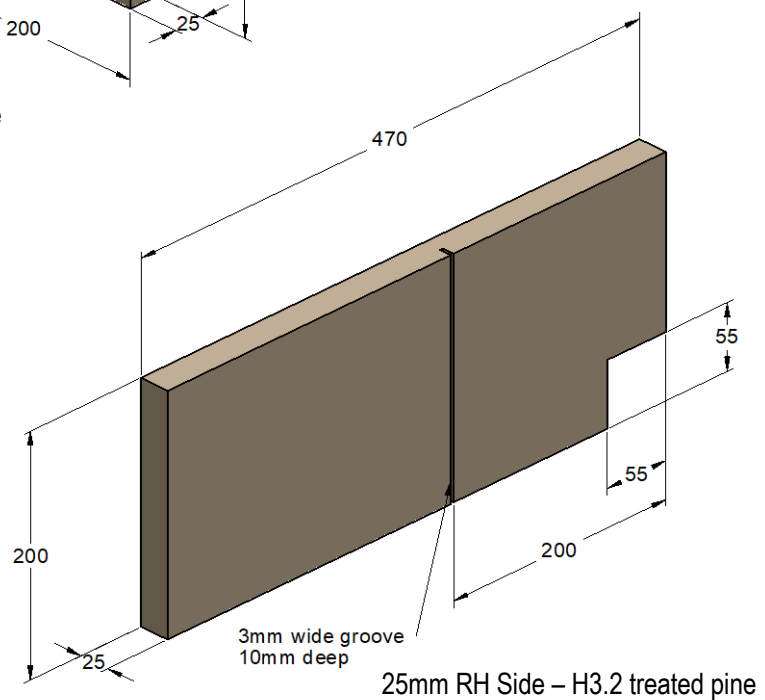

25mm RH Side – H3.2 treated pine

**1 Required**

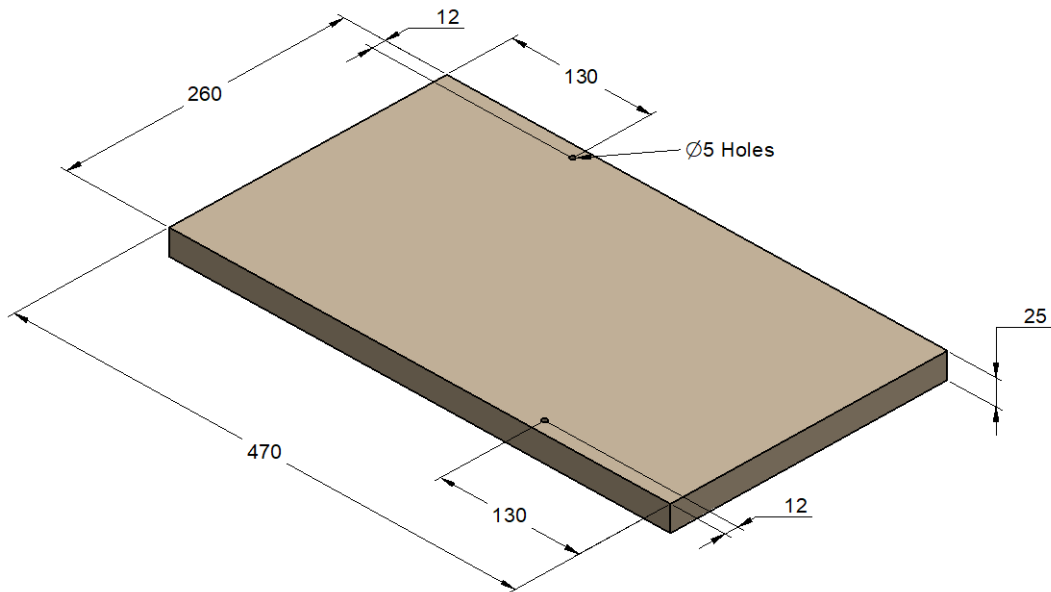

25mm Top – H3.2 treated pine or 24mm Marine Grade Plywood

**1 Required**

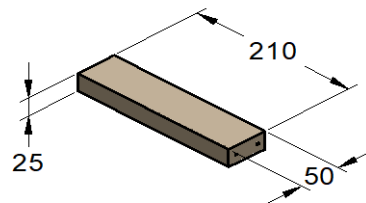

50x25mm Spacer – H3.2 treated pine

**2 Required**

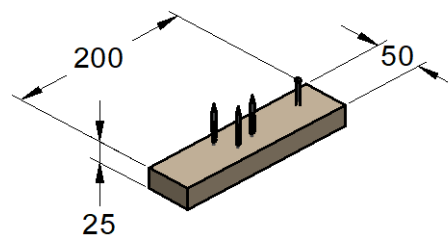

50x25mm Bait Block – H3.2 treated pine

**1 Required**

Fitted with 3 nails facing up for holding bait & 1 nail for securing to the base

Assemble Components ...

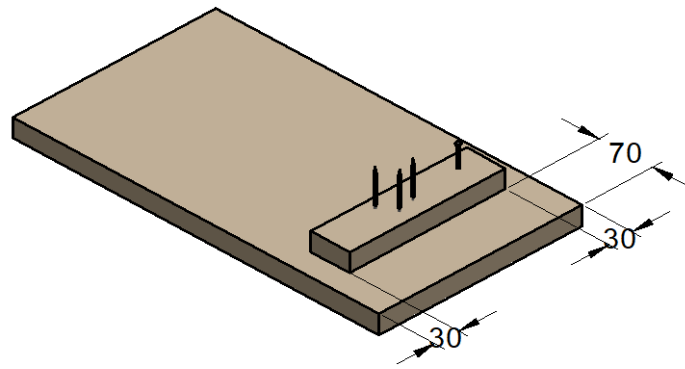

1 - Nail Bait Block to the Base with a single Nail

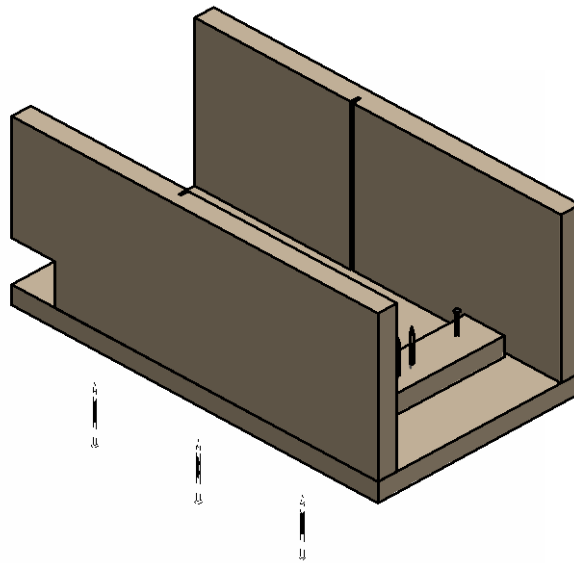

2 - Nail Base Assembly to LH & RH Sides with 6 Nails

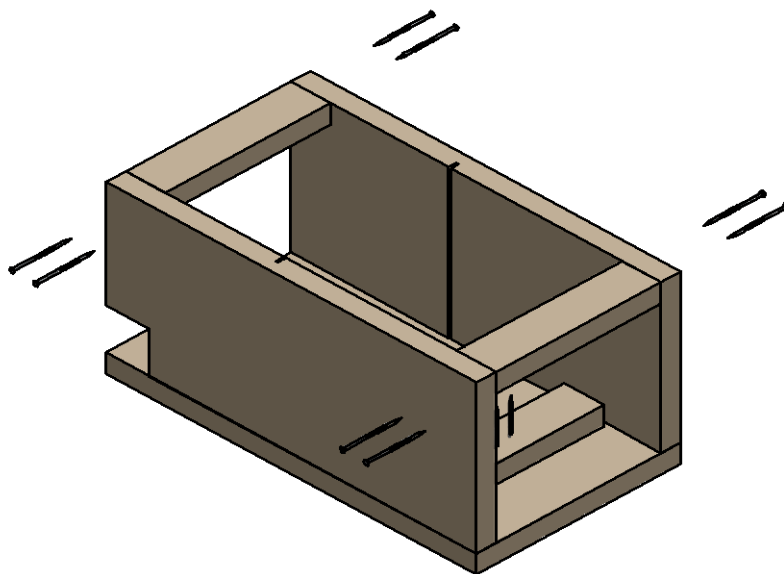

3 - Nail Spacers in place with 8 Nails

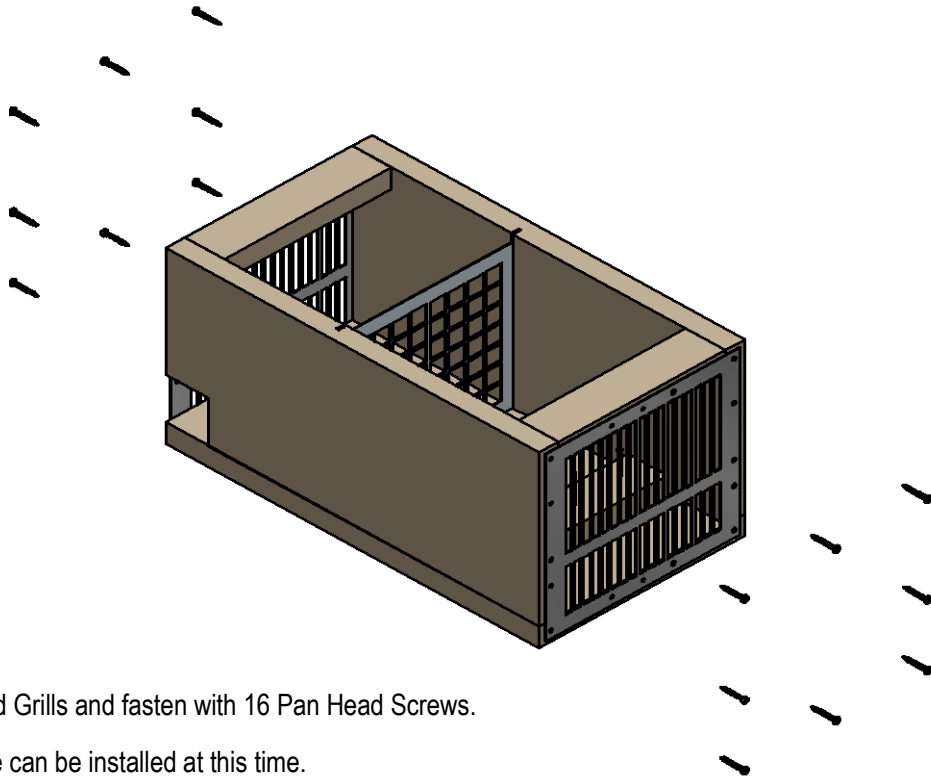

**4 - Fit End Grills and fasten with 16 Pan Head Screws.**

The baffle can be installed at this time.

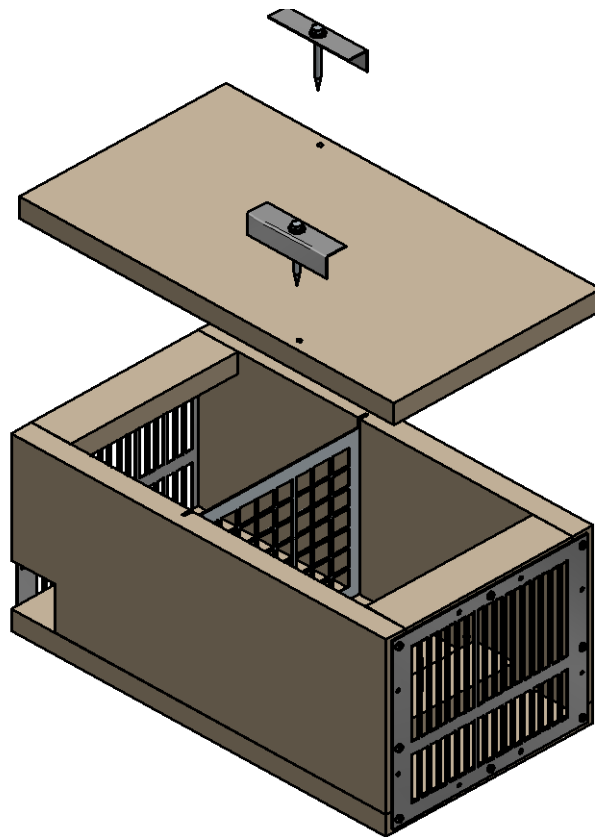

**5 - Fit Top using two Hex Screws and Brackets.**